



36" Integrated All Freezer— Tall

Integrated refrigeration can be used anywhere in the home. It merges seamlessly into the décor, with no visible hinges or grilles. Model 736TFI is a 36" wide tall unit with freezer storage in the upper cabinet and lower drawers. This model is ENERGY STAR® qualified for energy efficiency.



FEATURES

- Custom front panels and hardware allow for infinite design options.
- Point-of-use refrigeration that can be placed anywhere in the home.
- Microprocessor maintains precise control, within 1° of set temperature.
- Easy-access, illuminated touch control panel.
- Bright interior lighting in cabinet and drawers.
- Adjustable wire shelves and door shelves.
- Smooth-glide, full-extension storage drawers.
- Door alarm has an audible beep if door or drawer is left open.
- Automatic ice maker provides crescent shaped ice.
- 90° door stop built into hinge.
- Star-K compliant with harness kit.

MODEL

736TFI

Design

Integrated

INTERIOR FEATURES

- Freezer
 - 1 Temperature Zone
 - 3 Adjustable Wire Shelves
 - 1 Stationary Shelf
 - 2 Storage Drawers
 - 2 Removable Drawer Dividers
 - 4 Adjustable Door Shelves
- Automatic Defrost
- Automatic Ice Maker

ACCESSORIES

- Stainless steel front panels with tubular or pro handles—80" or 84" finished height.
- Stainless steel tubular and pro handles.
- Dual installation kits for installation with column, tall or drawer model.

Accessories are available through your Sub-Zero dealer. For local dealer information, visit the find a showroom section of our website, subzero.com.





36" Integrated All Freezer— Tall

OVERALL DIMENSIONS

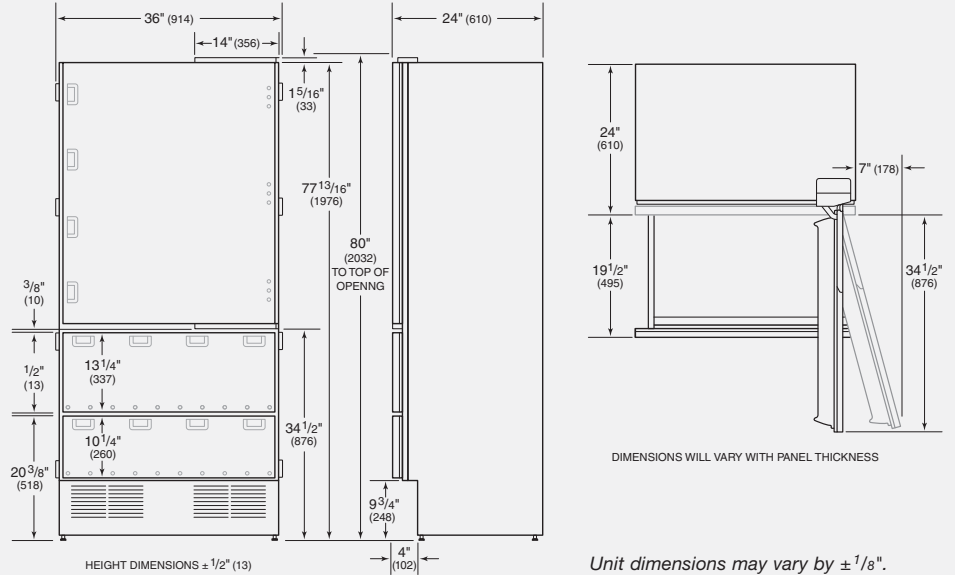

SPECIFICATIONS

Overall Width	36"
Overall Height	80"
Overall Depth	24"
Door Clearance	34 1/2"
Drawer Clearance	19 1/2"
Freezer Capacity	21.5 cu ft
Finished Opening	36" W x 80" H x 25" D*
Electrical Requirements	115 V AC, 60 Hz 15 amp dedicated circuit
Plumbing Requirements	1/4" OD copper line 20–100 psi
Annual Energy Usage	\$84**
Shipping Weight	480 lbs

*Depth is 24" from the front of the unit to its back. Your design may necessitate moving the unit back, or cabinets forward to achieve a flush fit. This will require a minimum opening depth of 25".

**Based on 10.65 cents per kilowatt hour.

INSTALLATION SPECIFICATIONS

Opening Dimensions

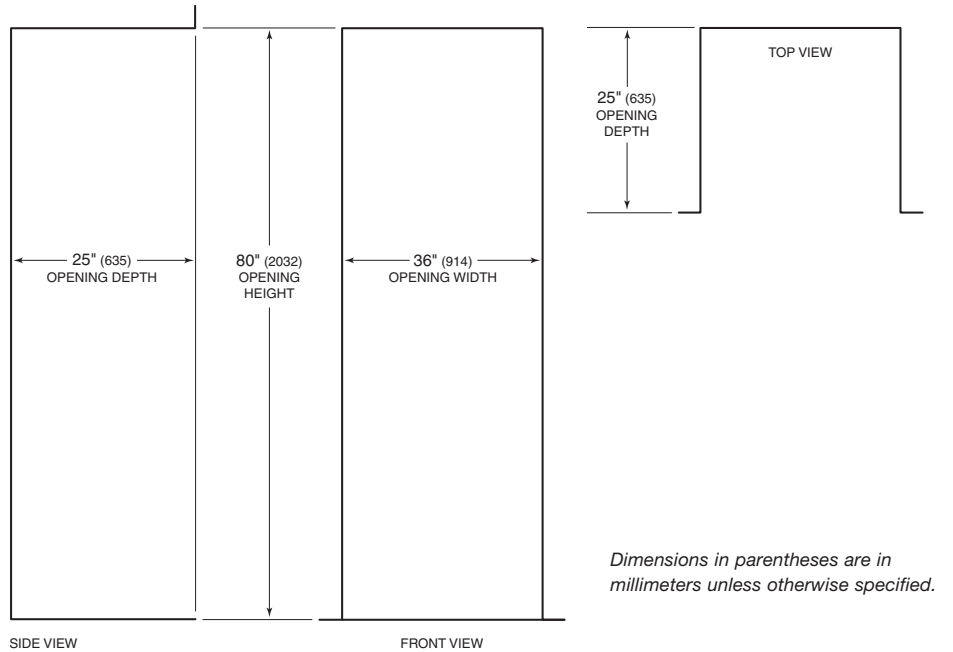

Location of Electrical Supply

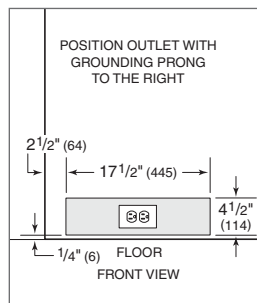

Location of Water Supply

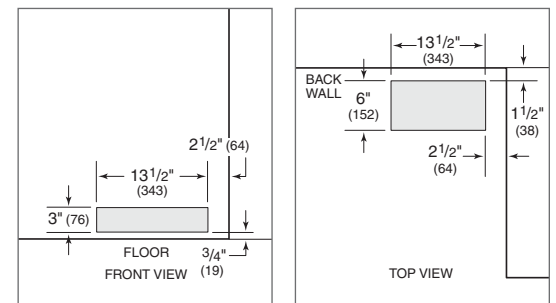

INSTALLATION NOTES

Stainless steel panels with handles are available as accessories. These panels are not installed at the factory.

Complete installation specifications, including panel sizes, can be found on our website, subzero.com/specs.