



## 27" Integrated All Freezer—Drawers

Integrated refrigeration can be used anywhere in the home. It merges seamlessly into the décor, with no visible hinges or grilles. Model 700BF(I) is a 27" wide base unit with freezer storage in both drawers. Model 700BFI features an automatic ice maker. This model is ENERGY STAR® qualified for energy efficiency.



### FEATURES

- Custom front panels and hardware allow for infinite design options.
- Point-of-use refrigeration that can be placed anywhere in the home.
- Microprocessor maintains precise control, within 1° of set temperature.
- Easy-access, illuminated touch control panel in upper freezer drawer.
- Bright interior lighting.
- Smooth-glide, full-extension storage drawers.
- Door alarm has an audible beep if drawer is left open.
- Automatic ice maker provides crescent shaped ice (700BFI).

### MODEL OPTIONS

	700BF	700BFI
Design	Integrated	Integrated
Automatic Ice Maker		•

### INTERIOR FEATURES

- **Freezer**
  - 1 Temperature Zone
  - 2 Storage Drawers
  - 2 Removable Drawer Dividers (700BF)
  - 1 Removable Drawer Divider (700BFI)
  - Automatic Defrost
  - Automatic Ice Maker (700BFI)

### ACCESSORIES

- Stainless steel front panels with tubular or pro handles.
- Stainless steel tubular and pro handles.
- Dual installation kits for installation with column, tall or drawer model.

Accessories are available through your Sub-Zero dealer. For local dealer information, visit the find a showroom section of our website, [subzero.com](http://subzero.com).





## 27" Integrated All Freezer—Drawers

### OVERALL DIMENSIONS

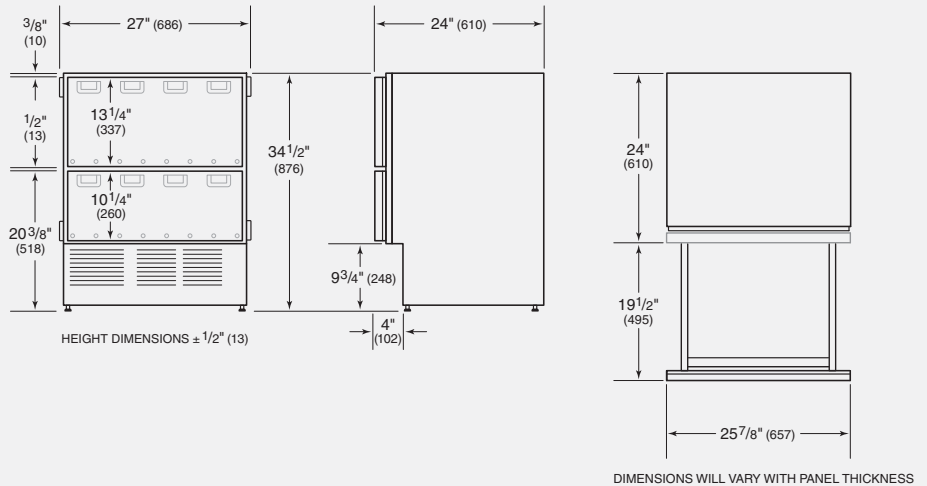

Unit dimensions may vary by  $\pm 1/8"$ .

### SPECIFICATIONS

Overall Width	27"
Overall Height	34 1/2"
Overall Depth	24"
Drawer Clearance	19 1/2"
Freezer Capacity	5.1 cu ft
Opening Width	27"
Opening Height	34 1/2"
Opening Depth	25"*
Electrical Requirements	115 V AC, 60 Hz 15 amp dedicated circuit
Plumbing Requirements (Model 700BFI)	1/4" OD copper line 20–100 psi
Annual Energy Usage	\$47**
Shipping Weight	190 lbs

\*Depth is 24" from the front of the unit to its back. Your design may necessitate moving the unit back, or cabinets forward to achieve a flush fit. This will require a minimum opening depth of 25".

\*\*Based on 10.65 cents per kilowatt hour.

### INSTALLATION NOTES

Stainless steel drawer front panels with handles are available as accessories. These panels are not installed at the factory.

Complete installation specifications, including panel sizes, can be found on our website, [subzero.com/specs](http://subzero.com/specs).

### INSTALLATION SPECIFICATIONS

#### Opening Dimensions

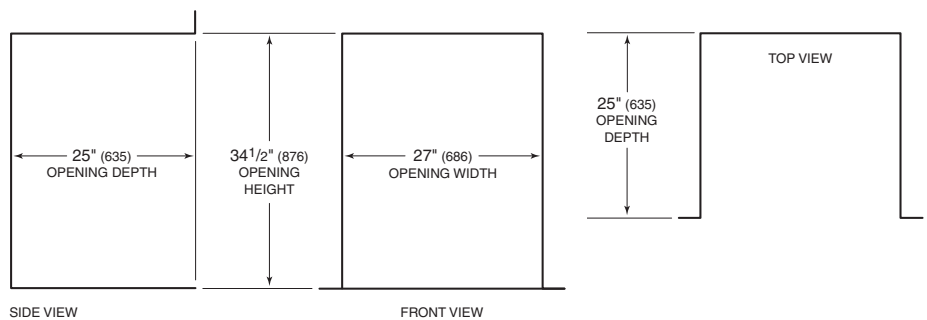

#### Location of Electrical Supply

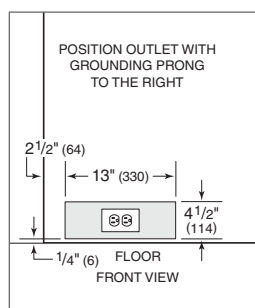

#### Location of Water Supply (Model 700BFI)

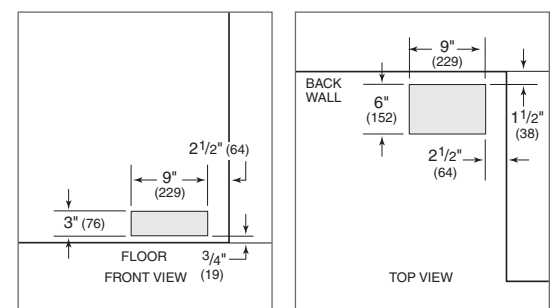

Dimensions in parentheses are in millimeters unless otherwise specified.